

A decorative graphic on the left side of the page, featuring a dashed circle, a solid blue circle, and several overlapping curved lines in light blue and grey.

Product Manual

## **Barracuda® 7200.9 PATA**

**ST3500841A  
ST3500641A  
ST3400833A  
ST3400633A  
ST3320833A  
ST3320633A  
ST3300822A  
ST3300622A  
ST3250824A  
ST3250624A**

**ST3200827A  
ST3160812A  
ST3160212A  
ST3120814A  
ST3120213A  
ST3802110A  
ST3402111A**

100389997  
Rev. F  
August 2007

©2006-2007, Seagate Technology LLC All rights reserved.  
Publication number: 100389997, Rev. F  
August 2007

Seagate, Seagate Technology and the Wave logo are registered trademarks of Seagate Technology LLC in the United States and/or other countries. Barracuda, SeaTools and SeaTDD are either trademarks or registered trademarks of Seagate Technology LLC or one of its affiliated companies in the United States and/or other countries. All other trademarks or registered trademarks are the property of their respective owners.

One gigabyte, or GB, equals one billion bytes when referring to hard drive capacity. Accessible capacity may vary depending on operating environment and formatting. Quantitative usage examples for various applications are for illustrative purposes. Actual quantities will vary based on various factors, including file size, file format, features and application software. Seagate reserves the right to change, without notice, product offerings or specifications.

# Contents

<b>1.0</b>	<b>Introduction</b>	<b>1</b>
<b>2.0</b>	<b>Drive specifications</b>	<b>3</b>
2.1	Specification summary table	3
2.2	Formatted capacity	20
2.2.1	LBA mode	20
2.3	Default logical geometry	20
2.4	Recording and interface technology	21
2.5	Physical characteristics	22
2.6	Seek time	22
2.7	Start/stop times	22
2.8	Power specifications	23
2.8.1	Power consumption	23
2.8.2	Conducted noise	26
2.8.3	Voltage tolerance	26
2.8.4	Power-management modes	26
2.9	Environmental specifications	27
2.9.1	Ambient temperature	27
2.9.2	Temperature gradient	27
2.9.3	Humidity	27
2.9.4	Altitude	27
2.9.5	Shock	28
2.9.6	Vibration	28
2.10	Acoustics	29
2.11	Electromagnetic immunity	30
2.12	Reliability	31
2.13	Agency certification	31
2.13.1	Safety certification	31
2.13.2	Electromagnetic compatibility	31
2.13.3	FCC verification	32
2.14	Environmental protection	33
2.14.1	European Union Restriction of Hazardous Substances (RoHS)	33
2.15	Corrosive environment	33
<b>3.0</b>	<b>Configuring and mounting the drive</b>	<b>35</b>
3.1	Handling and static discharge precautions	35
3.2	Breather filter hole precautions	36
3.3	Jumper settings	37
3.3.1	Master/slave configuration	37
3.3.2	Cable-select option	37
3.3.3	Alternate capacity jumper	37
3.3.4	Ultra ATA/100 cable	38
3.4	Drive mounting	38
<b>4.0</b>	<b>ATA interface</b>	<b>41</b>
4.1	ATA interface signals and connector pins	41
4.1.1	Supported ATA commands	42
4.1.2	Identify Device command	44
4.1.3	Set Features command	48
4.1.4	S.M.A.R.T. commands	49
<b>5.0</b>	<b>Seagate Technology support services</b>	<b>51</b>



## List of Figures

Figure 1.	Typical 5V startup and operation current profile . . . . .	25
Figure 2.	Typical 12V startup and operation current profile . . . . .	25
Figure 3.	Breather filter hole location . . . . .	36
Figure 4.	Master/slave jumper settings . . . . .	37
Figure 5.	Ultra ATA cable connectors . . . . .	38
Figure 6.	Mounting dimensions—top, side and end view . . . . .	39
Figure 7.	I/O pins and supported ATA signals . . . . .	41



## 1.0 Introduction

---

This manual describes the functional, mechanical and interface specifications for the following Seagate® Barracuda® 7200.9 PATA model drives:

ST3500841A	ST3300822A	ST3160212A
ST3500641A	ST3300622A	ST3120814A
ST3400833A	ST3250824A	ST3120213A
ST3400633A	ST3250624A	ST3802110A
ST3320833A	ST3200827A	ST3402111A
ST3320633A	ST3160812A	

These drives provide the following key features:

- 7,200-RPM spindle speed
- High instantaneous (burst) data transfer rates (up to 100 Mbytes per second) using Ultra DMA mode 5.
- Tunneling Magnetoresistive (TMR) recording heads provide the drives with increased areal density.
- State-of-the-art cache and on-the-fly error-correction algorithms.
- Full-track multiple-sector transfer capability without local processor intervention.
- Quiet operation.
- 350 Gs nonoperating shock.
- SeaTools diagnostic software performs a drive self-test that eliminates unnecessary drive returns.
- Support for S.M.A.R.T. drive monitoring and reporting.
- Support for Read Multiple and Write Multiple commands.
- Support for autodetection of master/slave drives that use cable select (CSEL).





## 2.0 Drive specifications

---

Unless otherwise noted, all specifications are measured under ambient conditions, at 25°C, and nominal power. For convenience, the phrases *the drive* and *this drive* are used throughout this manual to indicate the following drive models:

ST3500841A	ST3300822A	ST3160212A
ST3500641A	ST3300622A	ST3120814A
ST3400833A	ST3250824A	ST3120213A
ST3400633A	ST3250624A	ST3802110A
ST3320833A	ST3200827A	ST3402111A
ST3320633A	ST3160812A	

### 2.1 Specification summary table

The specifications listed in the table below are for quick reference. For details on specification measurement or definition, see the appropriate section of this manual.

**Table 1: Drive specifications summary for 500 Gbyte models**

Drive specification	ST3500841A	ST3500641A
Formatted Gbytes (512 bytes/sector)*	500	
Guaranteed sectors	976,773,168	
Bytes per sector	512	
Default sectors per track	63	
Default read/write heads	16	
Default cylinders	16,383	
Recording density, KBPI (kbits/in max)	790.1	
Track density, KTPI (ktracks/in avg.)	124.5	
Areal density, (Gbits/in <sup>2</sup> avg)	97.96	
Spindle speed (RPM)	7,200	
Internal data transfer rate (Mbits/sec max)	815.2	
Sustained data transfer rate OD (Mbytes/sec max)	65.0	
I/O data-transfer rate (Mbytes/sec max)	100	
ATA data-transfer modes supported	PIO modes 0–4 Multiword DMA modes 0–2 Ultra DMA modes 0–5	
Cache buffer	8 Mbytes	16 Mbytes
Height (mm max)	26.1 mm (1.028 inches)	
Width (mm max)	101.6 mm (4.000 inches) +/- 0.010 inches	
Length (mm max)	146.99 mm (5.787 inches)	
Weight (max)	710 grams (1.57 lb.)	
Average latency (msec)	4.16	
Power-on to ready (sec max)	13.0 sec	
Standby to ready (sec max)	13.0 sec	
Track-to-track seek time (msec typical)	<0.8 (read), <1.0 (write)	
Average seek, read (msec typical)	<11.0	
Average seek, write (msec typical)	<12.0	
Startup current (typical) 12V (peak)	2.9 amps	
Voltage tolerance (including noise)	5V ± 5% 12V ± 10%	
Ambient temperature	0° to 60°C (operating) –40° to 70°C (nonoperating)	
Temperature gradient (°C per hour max)	20°C (operating) 30°C (nonoperating)	
Relative humidity	5% to 90% (operating) 5% to 95% (nonoperating)	
Relative humidity gradient	30% per hour max	
Wet bulb temperature (°C max)	37.7 (operating) 40.0 (nonoperating)	
Altitude, operating	–60.96 m to 3,048 m (–200 ft. to 10,000+ ft.)	
Altitude, nonoperating (below mean sea level, max)	–60.96 m to 12,192 m (–200 ft. to 40,000+ ft.)	
Operational Shock (max at 2 msec)	63 Gs	
Non-Operational Shock (max at 2 msec)	300 Gs	
Vibration, operating	5–22 Hz: 0.25 Gs, Limited displacement 22–350 Hz: 0.5 Gs 350–500 Hz: 0.25 Gs	

Drive specification	ST3500841A	ST3500641A
Vibration, nonoperating	5–22 Hz: 0.25 Gs, Limited displacement 22–350 Hz: 5.0 Gs 350–500 Hz: 1.0 Gs	
Drive acoustics, sound power (bels)		
Idle**	2.8 (typical) 3.0 (max)	
Quiet seek	3.2 (typical) 3.4 (max)	
Nonrecoverable read errors	1 per 10 <sup>14</sup> bits read	
Annualized Failure Rate (AFR)	0.34%	
Warranty	5 years on distribution units. To determine the warranty for a specific drive, use a web browser to access the following web page: <a href="http://www.seagate.com/support/service/">www.seagate.com/support/service/</a> From this page, click on the “Verify Your Warranty” link. You will be asked to provide the drive serial number, model number (or part number) and country of purchase. The system will display the warranty information for your drive.	
Contact start-stop cycles (25°C, 50% rel. humidity)	50,000	

**Table 2: Drive specifications summary for 400 Gbyte models**

Drive specification	ST3400633A	ST3400833A
Formatted Gbytes (512 bytes/sector)*	400	
Guaranteed sectors	781,422,768	
Bytes per sector	512	
Default sectors per track	63	
Default read/write heads	16	
Default cylinders	16,383	
Recording density, KBPI (kbits/in max)	790.1	
Track density, KTPI (ktracks/in avg.)	124.5	
Areal density, (Gbits/in <sup>2</sup> avg)	97.69	
Spindle speed (RPM)	7,200	
Internal data transfer rate (Mbits/sec max)	815.2	
Sustained data transfer rate OD (Mbytes/sec max)	65.0	
I/O data-transfer rate (Mbytes/sec max)	100	
ATA data-transfer modes supported	PIO modes 0–4 Multiword DMA modes 0–2 Ultra DMA modes 0–5	
Cache buffer	16 Mbytes	8 Mbytes
Height (mm max)	26.1 mm (1.028 inches)	
Width (mm max)	101.6 mm (4.000 inches) +/- 0.010 inches	
Length (mm max)	146.99 mm (5.787 inches)	
Weight (max)	710 grams (1.57 lb.)	
Average latency (msec)	4.16	
Power-on to ready (sec max)	13.0 sec	
Standby to ready (sec max)	13.0 sec	
Track-to-track seek time (msec typical)	<0.8 (read), <1.0 (write)	
Average seek, read (msec typical)	<11.0	
Average seek, write (msec typical)	<12.0	
Startup current (typical) 12V (peak)	2.9 amps	
Voltage tolerance (including noise)	5V ± 5% 12V ± 10%	
Ambient temperature	0° to 60°C (operating) –40° to 70°C (nonoperating)	
Temperature gradient (°C per hour max)	20°C (operating) 30°C (nonoperating)	
Relative humidity	5% to 90% (operating) 5% to 95% (nonoperating)	
Relative humidity gradient	30% per hour max	
Wet bulb temperature (°C max)	37.7 (operating) 40.0 (nonoperating)	
Altitude, operating	–60.96 m to 3,048 m (–200 ft. to 10,000+ ft.)	
Altitude, nonoperating (below mean sea level, max)	–60.96 m to 12,192 m (–200 ft. to 40,000+ ft.)	
Operational Shock (Gs max at 2 msec)	63	
Non-Operational Shock (Gs max at 2 msec)	300 Gs	
Vibration, operating	5–22 Hz: 0.25 Gs, Limited displacement 22–350 Hz: 0.5 Gs 350–500 Hz: 0.25 Gs	

Drive specification	ST3400633A	ST3400833A
Vibration, nonoperating	5–22 Hz: 0.25 Gs, Limited displacement 22–350 Hz: 5.0 Gs 350–500 Hz: 1.0 Gs	
Drive acoustics, sound power (bels) Idle**  Quiet seek	2.8 (typical) 3.0 (max)  3.2 (typical) 3.4 (max)	
Nonrecoverable read errors	1 per 10 <sup>14</sup> bits read	
Annualized Failure Rate (AFR)	0.34%	
Warranty	5 years on distribution units. To determine the warranty for a specific drive, use a web browser to access the following web page: <a href="http://www.seagate.com/support/service/">www.seagate.com/support/service/</a> From this page, click on the “Verify Your Warranty” link. You will be asked to provide the drive serial number, model number (or part number) and country of purchase. The system will display the warranty information for your drive.	
Contact start-stop cycles (25°C, 50% rel. humidity)	50,000	

**Table 3: Drive specifications summary for 320 Gbyte models**

Drive specification	ST3320633A	ST3320633A
Formatted Gbytes (512 bytes/sector)*	320	
Guaranteed sectors	625,142,448	
Bytes per sector	512	
Default sectors per track	63	
Default read/write heads	16	
Default cylinders	16,383	
Recording density, KBPI (kbits/in max)	790.1	
Track density, KTPI (ktracks/in avg.)	124.5	
Areal density, (Gbits/in <sup>2</sup> avg)	97.69	
Spindle speed (RPM)	7,200	
Internal data transfer rate (Mbits/sec max)	867.2	
Sustained data transfer rate OD (Mbytes/sec max)	76.6	
I/O data-transfer rate (Mbytes/sec max)	100	
ATA data-transfer modes supported	PIO modes 0–4 Multiword DMA modes 0–2 Ultra DMA modes 0–5	
Cache buffer	16 Mbytes	8 Mbytes
Height (mm max)	26.1 mm (1.028 inches)	
Width (mm max)	101.6 mm (4.000 inches) +/- 0.010 inches	
Length (mm max)	146.99 mm (5.787 inches)	
Weight (max)	655 grams (1.44 lb.)	
Average latency (msec)	4.16	
Power-on to ready (sec max)	11.0 sec	
Standby to ready (sec max)	11.0 sec	
Track-to-track seek time (msec typical)	<0.8 (read), <1.0 (write)	
Average seek, read (msec typical)	<11.0	
Average seek, write (msec typical)	<12.0	
Startup current (typical) 12V (peak)	2.8 amps	
Voltage tolerance (including noise)	5V ± 5% 12V ± 10%	
Ambient temperature	0° to 60°C (operating) –40° to 70°C (nonoperating)	
Temperature gradient (°C per hour max)	20°C (operating) 30°C (nonoperating)	
Relative humidity	5% to 90% (operating) 5% to 95% (nonoperating)	
Relative humidity gradient	30% per hour max	
Wet bulb temperature (°C max)	37.7 (operating) 40.0 (nonoperating)	
Altitude, operating	–60.96 m to 3,048 m (–200 ft. to 10,000+ ft.)	
Altitude, nonoperating (below mean sea level, max)	–60.96 m to 12,192 m (–200 ft. to 40,000+ ft.)	
Operational Shock (Gs max at 2 msec)	63	
Non-Operational Shock (Gs max at 2 msec)	300 Gs	
Vibration, operating	5–22 Hz: 0.25 Gs, Limited displacement 22–350 Hz: 0.5 Gs 350–500 Hz: 0.25 Gs	

Drive specification	ST3320633A	ST3320633A
Vibration, nonoperating	5–22 Hz: 0.25 Gs, Limited displacement 22–350 Hz: 5.0 Gs 350–500 Hz: 1.0 Gs	
Drive acoustics, sound power (bels)		
Idle**	2.7 (typical) 2.9 (max)	
Quiet seek	3.0 (typical) 3.2 (max)	
Nonrecoverable read errors	1 per 10 <sup>14</sup> bits read	
Annualized Failure Rate (AFR)	0.34%	
Warranty	5 years on distribution units. To determine the warranty for a specific drive, use a web browser to access the following web page: <a href="http://www.seagate.com/support/service/">www.seagate.com/support/service/</a> From this page, click on the “Verify Your Warranty” link. You will be asked to provide the drive serial number, model number (or part number) and country of purchase. The system will display the warranty information for your drive.	
Contact start-stop cycles (25°C, 50% rel. humidity)	50,000	

**Table 4: Drive specifications summary for 300 Gbyte models**

Drive specification	ST3300622A	ST3300822A
Formatted Gbytes (512 bytes/sector)*	300	
Guaranteed sectors	586,072,368	
Bytes per sector	512	
Default sectors per track	63	
Default read/write heads	16	
Default cylinders	16,383	
Recording density, KBPI (kbits/in max)	790.1	
Track density, KTPI (ktracks/in avg.)	124.5	
Areal density, (Gbits/in <sup>2</sup> avg)	97.69	
Spindle speed (RPM)	7,200	
Internal data transfer rate (Mbits/sec max)	867.2	
Sustained data transfer rate OD (Mbytes/sec max)	76.6	
I/O data-transfer rate (Mbytes/sec max)	100	
ATA data-transfer modes supported	PIO modes 0–4 Multiword DMA modes 0–2 Ultra DMA modes 0–5	
Cache buffer	16 Mbytes	8 Mbytes
Height (mm max)	26.1 mm (1.028 inches)	
Width (mm max)	101.6 mm (4.000 inches) +/- 0.010 inches	
Length (mm max)	146.99 mm (5.787 inches)	
Weight (max)	655 grams (1.44 lb.)	
Average latency (msec)	4.16	
Power-on to ready (sec max)	11.0 sec	
Standby to ready (sec max)	11.0 sec	
Track-to-track seek time (msec typical)	<0.8 (read), <1.0 (write)	
Average seek, read (msec typical)	<11.0	
Average seek, write (msec typical)	<12.0	
Startup current (typical) 12V (peak)	2.8 amps	
Voltage tolerance (including noise)	5V ± 5% 12V ± 10%	
Ambient temperature	0° to 60°C (operating) –40° to 70°C (nonoperating)	
Temperature gradient (°C per hour max)	20°C (operating) 30°C (nonoperating)	
Relative humidity	5% to 90% (operating) 5% to 95% (nonoperating)	
Relative humidity gradient	30% per hour max	
Wet bulb temperature (°C max)	37.7 (operating) 40.0 (nonoperating)	
Altitude, operating	–60.96 m to 3,048 m (–200 ft. to 10,000+ ft.)	
Altitude, nonoperating (below mean sea level, max)	–60.96 m to 12,192 m (–200 ft. to 40,000+ ft.)	
Operational Shock (Gs max at 2 msec)	63	
Non-Operational Shock (Gs max at 2 msec)	300 Gs	
Vibration, operating	5–22 Hz: 0.25 Gs, Limited displacement 22–350 Hz: 0.5 Gs 350–500 Hz: 0.25 Gs	



Drive specification	ST3300622A	ST3300822A
Vibration, nonoperating	5–22 Hz: 0.25 Gs, Limited displacement 22–350 Hz: 5.0 Gs 350–500 Hz: 1.0 Gs	
Drive acoustics, sound power (bels)		
Idle**	2.7 (typical) 2.9 (max)	
Quiet seek	3.0 (typical) 3.2 (max)	
Nonrecoverable read errors	1 per 10 <sup>14</sup> bits read	
Annualized Failure Rate (AFR)	0.34%	
Warranty	5 years on distribution units. To determine the warranty for a specific drive, use a web browser to access the following web page: <a href="http://www.seagate.com/support/service/">www.seagate.com/support/service/</a> From this page, click on the “Verify Your Warranty” link. You will be asked to provide the drive serial number, model number (or part number) and country of purchase. The system will display the warranty information for your drive.	
Contact start-stop cycles (25°C, 50% rel. humidity)	50,000	

**Table 5: Drive specifications summary for 250 and 200 Gbyte models**

Drive specification	ST3250624A	ST3250824A	ST3200827A
Formatted Gbytes (512 bytes/sector)*	250		200
Guaranteed sectors	488,397,168		390,721,968
Bytes per sector	512		
Default sectors per track	63		
Default read/write heads	16		
Default cylinders	16,383		
Recording density, KBPI (kbits/in max)	790.1		
Track density, KTPI (ktracks/in avg.)	124.5		
Areal density, (Gbits/in <sup>2</sup> avg)	97.69		
Spindle speed (RPM)	7,200		
Internal data transfer rate (Mbits/sec max)	867.2		
Sustained data transfer rate OD (Mbytes/sec max)	76.6		
I/O data-transfer rate (Mbytes/sec max)	100		
ATA data-transfer modes supported	PIO modes 0–4 Multiword DMA modes 0–2 Ultra DMA modes 0–5		
Cache buffer	16 Mbytes	8 Mbytes	
Height (mm max)	26.1 mm (1.028 inches)		
Width (mm max)	101.6 mm (4.000 inches) +/- 0.010 inches		
Length (mm max)	146.99 mm (5.787 inches)		
Weight (max)	580 grams (1.28 lb.)		
Average latency (msec)	4.16		
Power-on to ready (sec max)	11.0 sec		
Standby to ready (sec max)	11.0 sec		
Track-to-track seek time (msec typical)	<0.8 (read), <1.0 (write)		
Average seek, read (msec typical)	<11.0		
Average seek, write (msec typical)	<12.0		
Startup current (typical) 12V (peak)	2.8 amps		
Voltage tolerance (including noise)	5V ± 5% 12V ± 10%		
Ambient temperature	0° to 60°C (operating) –40° to 70°C (nonoperating)		
Temperature gradient (°C per hour max)	20°C (operating) 30°C (nonoperating)		
Relative humidity	5% to 90% (operating) 5% to 95% (nonoperating)		
Relative humidity gradient	30% per hour max		
Wet bulb temperature (°C max)	37.7 (operating) 40.0 (nonoperating)		
Altitude, operating	–60.96 m to 3,048 m (–200 ft. to 10,000+ ft.)		
Altitude, nonoperating (below mean sea level, max)	–60.96 m to 12,192 m (–200 ft. to 40,000+ ft.)		
Operational Shock (Gs max at 2 msec)	63		
Non-Operational Shock (Gs max at 2 msec)	350 Gs		
Vibration, operating	5–22 Hz: 0.25 Gs, Limited displacement 22–350 Hz: 0.5 Gs 350–500 Hz: 0.25 Gs		

Drive specification	ST3250624A	ST3250824A	ST3200827A
Vibration, nonoperating	5–22 Hz: 0.25 Gs, Limited displacement 22–350 Hz: 5.0 Gs 350–500 Hz: 1.0 Gs		
Drive acoustics, sound power (bels)			
Idle**	2.7 (typical) 2.9 (max)		
Quiet seek	3.0 (typical) 3.2 (max)		
Nonrecoverable read errors	1 per 10 <sup>14</sup> bits read		
Annualized Failure Rate (AFR)	0.34%		
Warranty	5 years on distribution units. To determine the warranty for a specific drive, use a web browser to access the following web page: <a href="http://www.seagate.com/support/service/">www.seagate.com/support/service/</a> From this page, click on the “Verify Your Warranty” link. You will be asked to provide the drive serial number, model number (or part number) and country of purchase. The system will display the warranty information for your drive.		
Contact start-stop cycles (25°C, 50% rel. humidity)	50,000		

**Table 6: Drive specifications summary for 160 Gbyte models**

Drive specification	ST3160812A	ST3160212A
Formatted Gbytes (512 bytes/sector)*	160	
Guaranteed sectors	312,581,808	
Bytes per sector	512	
Default sectors per track	63	
Default read/write heads	16	
Default cylinders	16,383	
Recording density, KBPI (kbits/in max)	840.0	
Track density, KTPI (ktracks/in avg.)	141.5	
Areal density, (Gbits/in <sup>2</sup> avg)	119.0	
Spindle speed (RPM)	7,200	
Internal data transfer rate (Mbits/sec max)	867.2	
Sustained data transfer rate OD (Mbytes/sec max)	83.0	
I/O data-transfer rate (Mbytes/sec max)	100	
ATA data-transfer modes supported	PIO modes 0–4 Multiword DMA modes 0–2 Ultra DMA modes 0–5	
Cache buffer	8 Mbytes	2 Mbytes
Height (mm max)	26.1 mm (1.028 inches)	
Width (mm max)	101.6 mm (4.000 inches) +/- 0.010 inches	
Length (mm max)	146.99 mm (5.787 inches)	
Weight (max)	580 grams (1.28 lb.)	
Average latency (msec)	4.16	
Power-on to ready (sec max)	<10.0 sec	
Standby to ready (sec max)	<10.0 sec	
Track-to-track seek time (msec typical)	<0.8 (read), <1.0 (write)	
Average seek, read (msec typical)	<11.0	
Average seek, write (msec typical)	<12.0	
Startup current (typical) 12V (peak)	2.8 amps	
Voltage tolerance (including noise)	5V ± 5% 12V ± 10%	
Ambient temperature	0° to 60°C (operating) –40° to 70°C (nonoperating)	
Temperature gradient (°C per hour max)	20°C (operating) 30°C (nonoperating)	
Relative humidity	5% to 90% (operating) 5% to 95% (nonoperating)	
Relative humidity gradient	30% per hour max	
Wet bulb temperature (°C max)	37.7 (operating) 40.0 (nonoperating)	
Altitude, operating	–60.96 m to 3,048 m (–200 ft. to 10,000+ ft.)	
Altitude, nonoperating (below mean sea level, max)	–60.96 m to 12,192 m (–200 ft. to 40,000+ ft.)	
Operational Shock (Gs max at 2 msec)	63	
Non-Operational Shock (Gs max at 2 msec)	350 Gs	
Vibration, operating	5–22 Hz: 0.25 Gs, Limited displacement 22–350 Hz: 0.5 Gs 350–500 Hz: 0.25 Gs	

Drive specification	ST3160812A	ST3160212A
Vibration, nonoperating	5–22 Hz: 0.25 Gs, Limited displacement 22–350 Hz: 5.0 Gs 350–500 Hz: 1.0 Gs	
Drive acoustics, sound power (bels) Idle**  Quiet seek	2.5 (typical) 2.7 (max)  2.8 (typical) 3.0 (max)	
Nonrecoverable read errors	1 per 10 <sup>14</sup> bits read	
Annualized Failure Rate (AFR)	0.34%	
Warranty	5 years on distribution units. To determine the warranty for a specific drive, use a web browser to access the following web page: <a href="http://www.seagate.com/support/service/">www.seagate.com/support/service/</a> From this page, click on the "Verify Your Warranty" link. You will be asked to provide the drive serial number, model number (or part number) and country of purchase. The system will display the warranty information for your drive.	
Contact start-stop cycles (25°C, 50% rel. humidity)	50,000	

**Table 7: Drive specifications summary for 120 Gbyte models**

Drive specification	ST3120814A	ST3120213A
Formatted Gbytes (512 bytes/sector)*	120	
Guaranteed sectors	234,441,648	
Bytes per sector	512	
Default sectors per track	63	
Default read/write heads	16	
Default cylinders	16,383	
Recording density, KBPI (kbits/in max)	840.0	
Track density, KTPI (ktracks/in avg.)	141.5	
Areal density, (Gbits/in <sup>2</sup> avg)	119.0	
Spindle speed (RPM)	7,200	
Internal data transfer rate (Mbits/sec max)	867.2	
Sustained data transfer rate OD (Mbytes/sec max)	83.0	
I/O data-transfer rate (Mbytes/sec max)	100	
ATA data-transfer modes supported	PIO modes 0–4 Multiword DMA modes 0–2 Ultra DMA modes 0–5	
Cache buffer	8 Mbytes	2 Mbytes
Height (mm max)	26.1 mm (1.028 inches)	
Width (mm max)	101.6 mm (4.000 inches) +/- 0.010 inches	
Length (mm max)	146.99 mm (5.787 inches)	
Weight (max)	580 grams (1.28 lb.)	
Average latency (msec)	4.16	
Power-on to ready (sec max)	<10.0 sec	
Standby to ready (sec max)	<10.0 sec	
Track-to-track seek time (msec typical)	<0.8 (read), <1.0 (write)	
Average seek, read (msec typical)	<11.0	
Average seek, write (msec typical)	<12.0	
Startup current (typical) 12V (peak)	2.8 amps	
Voltage tolerance (including noise)	5V ± 5% 12V ± 10%	
Ambient temperature	0° to 60°C (operating) –40° to 70°C (nonoperating)	
Temperature gradient (°C per hour max)	20°C (operating) 30°C (nonoperating)	
Relative humidity	5% to 90% (operating) 5% to 95% (nonoperating)	
Relative humidity gradient	30% per hour max	
Wet bulb temperature (°C max)	37.7 (operating) 40.0 (nonoperating)	
Altitude, operating	–60.96 m to 3,048 m (–200 ft. to 10,000+ ft.)	
Altitude, nonoperating (below mean sea level, max)	–60.96 m to 12,192 m (–200 ft. to 40,000+ ft.)	
Operational Shock (Gs max at 2 msec)	63	
Non-Operational Shock (Gs max at 2 msec)	350 Gs	
Vibration, operating	5–22 Hz: 0.25 Gs, Limited displacement 22–350 Hz: 0.5 Gs 350–500 Hz: 0.25 Gs	

<b>Drive specification</b>	<b>ST3120814A</b>	<b>ST3120213A</b>
Vibration, nonoperating	5–22 Hz: 0.25 Gs, Limited displacement 22–350 Hz: 5.0 Gs 350–500 Hz: 1.0 Gs	
Drive acoustics, sound power (bels)		
Idle**	2.5 (typical) 2.7 (max)	
Quiet seek	2.8 (typical) 3.0 (max)	
Nonrecoverable read errors	1 per 10 <sup>14</sup> bits read	
Annualized Failure Rate (AFR)	0.34%	
Warranty	5 years on distribution units. To determine the warranty for a specific drive, use a web browser to access the following web page: <a href="http://www.seagate.com/support/service/">www.seagate.com/support/service/</a> From this page, click on the "Verify Your Warranty" link. You will be asked to provide the drive serial number, model number (or part number) and country of purchase. The system will display the warranty information for your drive.	
Contact start-stop cycles (25°C, 50% rel. humidity)	50,000	

**Table 8: Drive specifications summary for 80 and 40 Gbyte models**

Drive specification	ST3802110A	ST3402111A
Formatted Gbytes (512 bytes/sector)*	80	40
Guaranteed sectors	156,301,488	78,165,360
Bytes per sector	512	
Default sectors per track	63	
Default read/write heads	16	
Default cylinders	16,383	
Recording density, KBPI (kbits/in max)	840.0	611.5
Track density, KTPI (ktracks/in avg.)	141.5	103.9
Areal density, (Gbits/in <sup>2</sup> avg)	119.0	63.53
Spindle speed (RPM)	7,200	
Internal data transfer rate (Mbits/sec max)	867.2	
Sustained data transfer rate OD (Mbytes/sec max)	83.0	69.4
I/O data-transfer rate (Mbytes/sec max)	100	
ATA data-transfer modes supported	PIO modes 0–4 Multiword DMA modes 0–2 Ultra DMA modes 0–5	
Cache buffer	2 Mbytes	
Height (mm max)	26.1 mm (1.028 inches)	
Width (mm max)	101.6 mm (4.000 inches) +/- 0.010 inches	
Length (mm max)	146.99 mm (5.787 inches)	
Weight (max)	580 grams (1.28 lb.)	525 grams (1.16 lb.)
Average latency (msec)	4.16	
Power-on to ready (sec max)	<10.0 sec	
Standby to ready (sec max)	<10.0 sec	
Track-to-track seek time (msec typical)	<0.8 (read), <1.0 (write)	
Average seek, read (msec typical)	<11.0	
Average seek, write (msec typical)	<12.0	
Startup current (typical) 12V (peak)	2.8 amps	
Voltage tolerance (including noise)	5V ± 5% 12V ± 10%	
Ambient temperature	0° to 60°C (operating) –40° to 70°C (nonoperating)	
Temperature gradient (°C per hour max)	20°C (operating) 30°C (nonoperating)	
Relative humidity	5% to 90% (operating) 5% to 95% (nonoperating)	
Relative humidity gradient	30% per hour max	
Wet bulb temperature (°C max)	37.7 (operating) 40.0 (nonoperating)	
Altitude, operating	–60.96 m to 3,048 m (–200 ft. to 10,000+ ft.)	
Altitude, nonoperating (below mean sea level, max)	–60.96 m to 12,192 m (–200 ft. to 40,000+ ft.)	
Operational Shock (Gs max at 2 msec)	63	
Non-Operational Shock (Gs max at 2 msec)	350 Gs	
Vibration, operating	5–22 Hz: 0.25 Gs, Limited displacement 22–350 Hz: 0.5 Gs 350–500 Hz: 0.25 Gs	



Drive specification	ST3802110A	ST3402111A
Vibration, nonoperating	5–22 Hz: 0.25 Gs, Limited displacement 22–350 Hz: 5.0 Gs 350–500 Hz: 1.0 Gs	
Drive acoustics, sound power (bels)		
Idle**	2.5 (typical) 2.7 (max)	2.0 (typical) 2.3 (max)
Quiet seek	2.7 (typical) 2.9 (max)	2.4 (typical) 2.6 (max)
Nonrecoverable read errors	1 per 10 <sup>14</sup> bits read	
Annualized Failure Rate (AFR)	0.34%	
Warranty	5 years on distribution units. To determine the warranty for a specific drive, use a web browser to access the following web page: <a href="http://www.seagate.com/support/service/">www.seagate.com/support/service/</a> From this page, click on the "Verify Your Warranty" link. You will be asked to provide the drive serial number, model number (or part number) and country of purchase. The system will display the warranty information for your drive.	
Contact start-stop cycles (25°C, 50% rel. humidity)	50,000	

\*One Gbyte equals one billion bytes when referring to hard drive capacity. Accessible capacity may vary depending on operating environment and formatting.

\*\*During periods of drive idle, some offline activity may occur according to the S.M.A.R.T. specification, which may increase acoustic and power to operational levels.

## 2.2 Formatted capacity

Model	Formatted capacity*	Guaranteed sectors	Bytes per sector
ST3500841A	500 Gbytes	976,773,168	512
ST3500641A	500 Gbytes	976,773,168	512
ST3400833A	400 Gbytes	781,422,768	512
ST3400633A	400 Gbytes	781,422,768	512
ST3320833A	320 Gbytes	625,142,448	512
ST3320633A	320 Gbytes	625,142,448	512
ST3300822A	300 Gbytes	586,072,368	512
ST3300622A	300 Gbytes	586,072,368	512
ST3250824A	250 Gbytes	488,397,168	512
ST3250624A	250 Gbytes	488,397,168	512
ST3200827A	200 Gbytes	390,721,968	512
ST3160812A	160 Gbytes	312,581,808	512
ST3160212A	160 Gbytes	312,581,808	512
ST3120814A	120 Gbytes	234,441,648	512
ST3120213A	120 Gbytes	234,441,648	512
ST3802110A	80 Gbytes	156,301,488	512
ST3402111A	40 Gbytes	78,165,360	512

\*One Gbyte equals one billion bytes when referring to hard drive capacity. Accessible capacity may vary depending on operating environment and formatting.

### 2.2.1 LBA mode

When addressing these drives in LBA mode, all blocks (sectors) are consecutively numbered from 0 to  $n-1$ , where  $n$  is the number of guaranteed sectors as defined above.

See Section 4.1.2, "Identify Device command" (words 60-61 and 100-103) for additional information about 48-bit addressing support of drives with capacities over 137 Gbytes.

## 2.3 Default logical geometry

Cylinders	Read/write heads	Sectors per track
16,383	16	63

## 2.4 Recording and interface technology

Interface	ATA
Recording method	16/17 EPRML
Recording density KBPI (kbits/inch max)	790.1 (500, 400, 320, 300, 250 and 200GB models) 840.0 (160, 120 and 80GB models) 611.5 (40GB model)
Track density KTPI (ktracks/inch avg)	124.5 (500, 400, 320, 300, 250 and 200GB models) 141.5 (160, 120 and 80GB models) 103.9 (40GB model)
Areal density (Gbits/inch <sup>2</sup> avg)	97.69 (500, 400, 320, 300, 250 and 200GB models) 119.0 (160, 120 and 80GB models) 63.53 (40GB model)
Spindle speed (RPM) (± 0.2%)	7,200
Internal data-transfer rate (Mbits/sec max)	815.2 (400 and 500GB models) 867.2 (all other models)
Sustained data transfer rate OD (Mbytes/sec max)	65.0 (400 and 500GB models) 76.6 (320, 300, 250 and 200GB models) 83.0 (160, 120 and 80GB models) 69.4 (40GB model)
I/O data-transfer rate (Mbytes/sec max)	100 (Ultra DMA mode 5)
Interleave	1:1
Cache buffer	
ST3500641A ST3400633A ST3320633A ST3300622A ST3250624A	16 Mbytes (16,384 kbytes)
ST3500841A ST3400833A ST3320833A ST3300822A ST3250824A ST3200827A ST3160812A ST3120814A	8 Mbytes (8,192 kbytes)
ST3160212A ST3120213A ST3802110A ST3402111A	2 Mbytes (2,048 kbytes)

## 2.5 Physical characteristics

<b>Drive specification</b>		
Maximum height	(mm) (inches)	26.1 1.028
Maximum width	(mm) (inches)	101.6 4.000 +/- 0.010
Maximum length	(mm) (inches)	146.99 5.787
Max weight	40GB models 250, 200, 160, 120 and 80GB models 300 and 320 GB models 400 and 500GB models	525 grams (1.16 lbs) 580 grams (1.28 lbs) 655 grams (1.44 lbs) 710 grams (1.57 lbs)

## 2.6 Seek time

Seek measurements are taken with nominal power at 25°C ambient temperature. All times are measured using drive diagnostics. The specifications in the table below are defined as follows:

- Track-to-track seek time is an average of all possible single-track seeks in both directions.
- Average seek time is a true statistical random average of at least 5,000 measurements of seeks between random tracks, less overhead.

<b>*Typical seek times (msec)</b>	<b>Read</b>	<b>Write</b>
Track-to-track	<0.8	<1.0
Average	<11.0	<12.0
Average latency:	4.16	

\*Measured in quiet mode

**Note.** These drives are designed to consistently meet the seek times represented in this manual. Physical seeks, regardless of mode (such as track-to-track and average), are expected to meet or exceed the noted values. However, due to the manner in which these drives are formatted, benchmark tests that include command overhead or measure logical seeks may produce results that vary from these specifications.

## 2.7 Start/stop times

	<b>400 and 500GB models</b>	<b>320, 300, 250 and 200GB models</b>	<b>160, 120, 80 and 40GB models</b>
Power-on to Ready (sec)	13 (max)	11 (max)	<10 (max)
Standby to Ready (sec)	13 (max)	11 (max)	<10 (max)
Ready to spindle stop (sec)	14 (max)	12 (max)	<11 (max)

## 2.8 Power specifications

The drive receives DC power (+5V or +12V) through a four-pin standard drive power connector.

### 2.8.1 Power consumption

Power requirements for the drives are listed in the table on page 25. Typical power measurements are based on an average of drives tested, under nominal conditions, using +5.0V and +12.0V input voltage at 25°C ambient temperature.

- **Spinup power**

Spinup power is measured from the time of power-on to the time that the drive spindle reaches operating speed.

- **Seek mode**

During seek mode, the read/write actuator arm moves toward a specific position on the disc surface and does not execute a read or write operation. Servo electronics are active. Seek mode power represents the worst-case power consumption, using only random seeks with read or write latency time. This mode is not typical and is provided for worst-case information.

- **Read/write power and current**

Read/write power is measured with the heads on track, based on a 16-sector write followed by a 32-msec delay, then a 16-sector read followed by a 32-msec delay.

- **Operating power and current**

Operating power is measured using 40 percent random seeks, 40 percent read/write mode (1 write for each 10 reads) and 20 percent drive idle mode.

- **Idle mode power**

Idle mode power is measured with the drive up to speed, with servo electronics active and with the heads in a random track location.

- **Standby mode**

During Standby mode, the drive accepts commands, but the drive is not spinning, and the servo and read/write electronics are in power-down mode.

**Table 9: DC power requirements (for 400GB and 500GB models)**

Power dissipation (watts)	Avg (watts, 25° C)	Avg 5V typ amps	Avg 12V typ amps
Spinup	—	—	2.90 (peak)
Idle*	9.30	0.611	0.520
Idle* (with offline activity)	10.40	0.719	0.567
Operating (40% r/w, 40% seek, 20% inop.)	13.00	0.772	0.762
Seeking (random, 20% idle)	12.60	0.613	0.795
Standby	0.80	0.106	0.023
Sleep	0.80	0.106	0.023

**Table 10: DC power requirements (for 320 and 300GB models)**

Power dissipation (watts)	Avg (watts, 25° C)	Avg 5V typ amps	Avg 12V typ amps
Spinup	—	—	2.80 (peak)
Idle*	7.40	0.393	0.453
Idle* (with offline activity)	9.40	0.483	0.582
Operating (40% r/w, 40% seek, 20% inop.)	13.00	0.811	0.746
Seeking (random, 20% idle)	12.80	0.471	0.870
Standby	0.80	0.112	0.02
Sleep	0.80	0.112	0.02

**Table 11: DC power requirements (for 250GB and 200GB models)**

Power dissipation (watts)	Avg (watts, 25° C)	Avg 5V typ amps	Avg 12V typ amps
Spinup	—	—	2.80 (peak)
Idle*	7.20	0.382	0.441
Idle* (with offline activity)	9.10	0.491	0.554
Operating (40% r/w, 40% seek, 20% inop.)	12.80	0.687	0.781
Seeking (random, 20% idle)	12.40	0.446	0.848
Standby	0.80	0.113	0.020
Sleep	0.80	0.110	0.021

**Table 12: DC power requirements (for 160GB and 120GB models)**

Power dissipation (watts)	Avg (watts, 25° C)	Avg 5V typ amps	Avg 12V typ amps
Spinup	—	—	2.80 (peak)
Idle*	7.20	0.590	0.354
Idle* (with offline activity)	9.10	0.880	0.391
Operating (40% r/w, 40% seek, 20% inop.)	12.80	0.920	0.682
Seeking (random, 20% idle)	12.40	0.690	0.745
Standby	0.80	0.113	0.020
Sleep	0.80	0.113	0.020

**Table 13: DC power requirements (for 80GB and 40GB models)**

Power dissipation (watts)	Avg (watts, 25° C)	Avg 5V typ amps	Avg 12V typ amps
Spinup	—	—	2.80 (peak)
Idle*	7.00	0.490	0.379
Idle* (with offline activity)	8.90	0.873	0.378
Operating (40% r/w, 40% seek, 20% inop.)	12.60	0.897	0.676
Seeking (random, 20% idle)	12.20	0.627	0.755
Standby	0.80	0.116	0.018
Sleep	0.80	0.116	0.018

\*During periods of drive idle, some offline activity may occur according to the S.M.A.R.T. specification, which may increase acoustic and power to operational levels.

### 2.8.1.1 Typical current profile

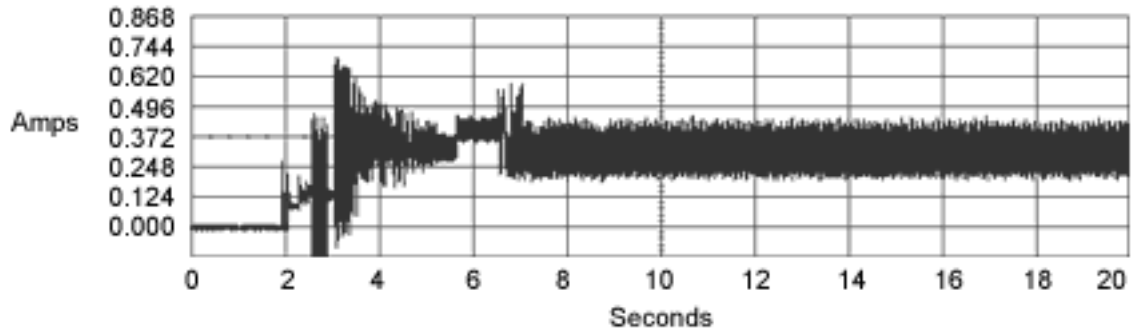

**Figure 1 Typical 5V startup and operation current profile**

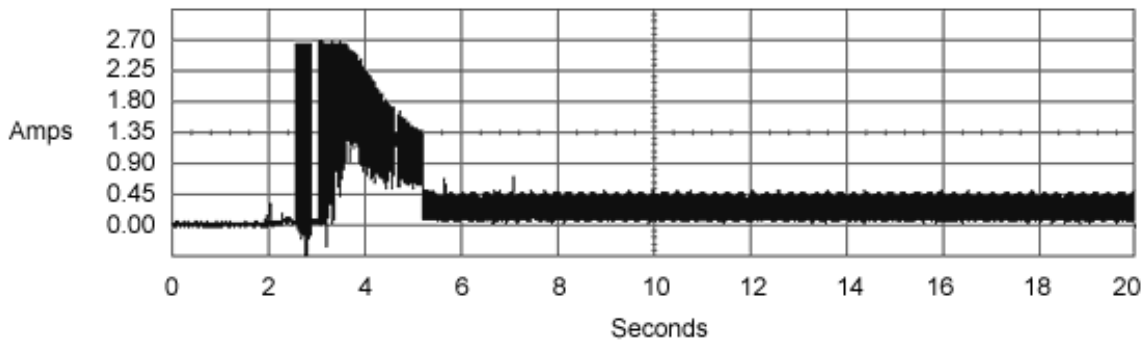

**Figure 2 Typical 12V startup and operation current profile**

## 2.8.2 Conducted noise

Input noise ripple is measured at the host system power supply across an equivalent 80-ohm resistive load on the +12 volt line or an equivalent 15-ohm resistive load on the +5 volt line.

- Using 12-volt power, the drive is expected to operate with a maximum of 120 mV peak-to-peak square-wave injected noise at up to 10 MHz.
- Using 5-volt power, the drive is expected to operate with a maximum of 100 mV peak-to-peak square-wave injected noise at up to 10 MHz.

**Note.** Equivalent resistance is calculated by dividing the nominal voltage by the typical RMS read/write current.

## 2.8.3 Voltage tolerance

Voltage tolerance (including noise):

5V  $\pm$  5%  
12V  $\pm$  10%

## 2.8.4 Power-management modes

The drive provides programmable power management to provide greater energy efficiency. In most systems, you can control power management through the system setup program. The drive features the following power-management modes:

Power mode	Heads	Spindle	Buffer
Active	Tracking	Rotating	Enabled
Idle	Tracking	Rotating	Enabled
Standby	Parked	Stopped	Enabled
Sleep	Parked	Stopped	Disabled

- **Active mode**

The drive is in Active mode during the read/write and seek operations.

- **Idle mode**

The buffer remains enabled, and the drive accepts all commands and returns to Active mode any time disc access is necessary.

- **Standby mode**

The drive enters Standby mode when the host sends a Standby Immediate command. If the host has set the standby timer, the drive can also enter Standby mode automatically after the drive has been inactive for a specifiable length of time. The standby timer delay is established using a Standby or Idle command. In Standby mode, the drive buffer is enabled, the heads are parked and the spindle is at rest. The drive accepts all commands and returns to Active mode any time disc access is necessary.

- **Sleep mode**

The drive enters Sleep mode after receiving a Sleep command from the host. In Sleep mode, the drive buffer is disabled, the heads are parked and the spindle is at rest. The drive leaves Sleep mode after it receives a Hard Reset or Soft Reset from the host. After receiving a reset, the drive exits Sleep mode and enters Standby mode with all current translation parameters intact.

- **Idle and Standby timers**

Each time the drive performs an Active function (read, write or seek), the standby timer is reinitialized and begins counting down from its specified delay times to zero. If the standby timer reaches zero before any drive



activity is required, the drive makes a transition to Standby mode. In both Idle and Standby mode, the drive accepts all commands and returns to Active mode when disc access is necessary.

## 2.9 Environmental specifications

### 2.9.1 Ambient temperature

Ambient temperature is defined as the temperature of the environment immediately surrounding the drive. Actual drive case temperature should not exceed 69°C (156°F) within the operating ambient conditions. Recommended measurement locations are shown in See Figure 6 on page 39.

Above 1,000 feet (305 meters), the maximum temperature is derated linearly to 112°F (44°C) at 10,000 feet (3,048 meters).

Operating:	0° to 60°C (32° to 140°F)
Nonoperating:	-40° to 70°C (-40° to 158°F)

### 2.9.2 Temperature gradient

Operating:	20°C per hour (68°F per hour max), without condensation
Nonoperating:	30°C per hour (86°F per hour max)

### 2.9.3 Humidity

#### 2.9.3.1 Relative humidity

Operating:	5% to 90% noncondensing (30% per hour max)
Nonoperating:	5% to 95% noncondensing (30% per hour max)

#### 2.9.3.2 Wet bulb temperature

Operating:	37.7°C (99.9°F max)
Nonoperating:	40.0°C (104°F max)

### 2.9.4 Altitude

Operating:	-60.96 m to 3,048 m (-200 ft. to 10,000+ ft.)
Nonoperating:	-60.96 m to 12,192 m (-200 ft. to 40,000+ ft.)

## 2.9.5 Shock

All shock specifications assume that the drive is mounted securely with the input shock applied at the drive mounting screws. Shock may be applied in the X, Y or Z axis.

### 2.9.5.1 Operating shock

These drives comply with the performance levels specified in this document when subjected to a maximum operating shock of 63 Gs based on half-sine shock pulses of 2 msec. Shocks should not be repeated more than two times per second.

### 2.9.5.2 Nonoperating shock

The nonoperating shock level that the drive can experience without incurring physical damage or degradation in performance when subsequently put into operation is 300 Gs (500, 400, 320, and 300GB models), 350 Gs (250, 200, 160, 120, 80 and 40GB models) based on a nonrepetitive half-sine shock pulse of 2 msec duration.

## 2.9.6 Vibration

All vibration specifications assume that the drive is mounted securely with the input vibration applied at the drive mounting screws. Vibration may be applied in the X, Y or Z axis.

### 2.9.6.1 Operating vibration

The following table lists the maximum vibration levels that the drive may experience while meeting the performance standards specified in this document.

5–22 Hz	0.25 Gs (Limited displacement)
23–350 Hz	0.50 Gs
350–500 Hz	0.25 Gs

### 2.9.6.2 Nonoperating vibration

The following table lists the maximum nonoperating vibration that the drive may experience without incurring physical damage or degradation in performance when subsequently put into operation.

5–22 Hz	0.25 Gs (limited displacement)
23–350 Hz	5.0 Gs
350–500 Hz	1.0 Gs

## 2.10 Acoustics

Drive acoustics are measured as overall A-weighted acoustic sound power levels (no pure tones). All measurements are consistent with ISO document 7779. Sound power measurements are taken under essentially free-field conditions over a reflecting plane. For all tests, the drive is oriented with the cover facing upward.

**Note.** For seek mode tests, the drive is placed in seek mode only. The number of seeks per second is defined by the following equation:

$$(\text{Number of seeks per second} = 0.4 / (\text{average latency} + \text{average access time}))$$

**Table 14: Fluid Dynamic Bearing (FDB) motor acoustics**

Acoustic mode		
	Idle*	Quiet seek
ST3402111A	2.0 bels (typ) 2.3 bels (max)	2.4 bels (typ) 2.6 bels (max)
ST3802110A	2.5 bels (typ) 2.7 bels (max)	2.7 bels (typ) 2.9 bels (max)
ST3120213A, ST3120814A, ST3160212A, ST3160812A	2.5 bels (typ) 2.7 bels (max)	2.8 bels (typ) 3.0 bels (max)
ST3200827A, ST3250824A, ST3250624A, ST3320833A, ST3320633A, ST3300622A, ST3300822A	2.7 bels (typ) 2.9 bels (max)	3.0 bels (typ) 3.2 bels (max)
ST3500641A, ST3500841A, ST3400633A, ST3400833A	2.8 bels (typ) 3.0 bels (max)	3.2 bels (typ) 3.4 bels (max)

\*During periods of drive idle, some offline activity may occur according to the S.M.A.R.T. specification, which may increase acoustic and power to operational levels.

## 2.11 Electromagnetic immunity

When properly installed in a representative host system, the drive operates without errors or degradation in performance when subjected to the radio frequency (RF) environments defined in the following table:

**Table 15: Radio frequency environments**

Test	Description	Performance level	Reference standard
Electrostatic discharge	Contact, HCP, VCP: $\pm 4$ kV; Air: $\pm 8$ kV	B	EN 61000-4-2: 95
Radiated RF immunity	80 to 1,000 MHz, 3 V/m, 80% AM with 1 kHz sine 900 MHz, 3 V/m, 50% pulse modulation @ 200 Hz	A	EN 61000-4-3: 96 ENV 50204: 95
Electrical fast transient	$\pm 1$ kV on AC mains, $\pm 0.5$ kV on external I/O	B	EN 61000-4-4: 95
Surge immunity	$\pm 1$ kV differential, $\pm 2$ kV common, AC mains	B	EN 61000-4-5: 95
Conducted RF immunity	150 kHz to 80 MHz, 3 Vrms, 80% AM with 1 kHz sine	A	EN 61000-4-6: 97
Voltage dips, interrupts	0% open, 5 seconds 0% short, 5 seconds 40%, 0.10 seconds 70%, 0.01 seconds	C C C B	EN 61000-4-11: 94

## 2.12 Reliability

Nonrecoverable read errors	1 per $10^{14}$ bits read, max.
Annualized Failure Rate (AFR)	0.34% (nominal power, 25°C ambient temperature)
Contact start-stop cycles	50,000 cycles (at nominal voltage and temperature, with 60 cycles per hour and a 50% duty cycle)
Warranty	5 years on distribution units. To determine the warranty for a specific drive, use a web browser to access the following web page: <a href="http://www.seagate.com/support/service/">www.seagate.com/support/service/</a> From this page, click on the "Verify Your Warranty" link. You will be asked to provide the drive serial number, model number (or part number) and country of purchase. The system will display the warranty information for your drive.
Preventive maintenance	None required.

## 2.13 Agency certification

### 2.13.1 Safety certification

The drives are recognized in accordance with UL 1950 and CSA C22.2 (950) and meet all applicable sections of IEC950 and EN 60950 as tested by TUV North America.

### 2.13.2 Electromagnetic compatibility

Hard drives that display the CE mark comply with the European Union (EU) requirements specified in the Electromagnetic Compatibility Directive (89/336/EEC). Testing is performed to the levels specified by the product standards for Information Technology Equipment (ITE). Emission levels are defined by EN 55022, Class B and the immunity levels are defined by EN 55024.

Seagate uses an independent laboratory to confirm compliance with the EC directives specified in the previous paragraph. Drives are tested in representative end-user systems. Although CE-marked Seagate drives comply with the directives when used in the test systems, we cannot guarantee that all systems will comply with the directives. The drive is designed for operation inside a properly designed enclosure, with properly shielded I/O cable (if necessary) and terminators on all unused I/O ports. Computer manufacturers and system integrators should confirm EMC compliance and provide CE marking for their products.

#### Korean RRL

If these drives have the Korea Ministry of Information and Communication (MIC) logo, they comply with paragraph 1 of Article 11 of the Electromagnetic Compatibility control Regulation and meet the Electromagnetic Compatibility (EMC) Framework requirements of the Radio Research Laboratory (RRL) Ministry of Information and Communication Republic of Korea.

These drives have been tested and comply with the Electromagnetic Interference/Electromagnetic Susceptibility (EMI/EMS) for Class B products. Drives are tested in a representative, end-user system by a Korean-recognized lab.

- EUT name (model numbers): See table below
- Certificate numbers:

Model	Certificate Number
ST3500841A, ST3500641A, ST3400833A, ST3400633A, ST3320833A, ST3320633A, ST3300822A, ST3300622A, ST3250824A, ST3250624A, ST3200827A, ST3160812A, ST3160212A, ST3120814A, ST3120213A, ST3802110A, ST3402111A	E-H011-05-3453 (B)

- Trade name or applicant: Seagate Technology
- Manufacturing date: September 2005
- Manufacturer/nationality: Singapore and China

#### Australian C-Tick (N176)

If these models have the C-Tick marking, they comply with the Australia/New Zealand Standard AS/NZS3548 1995 and meet the Electromagnetic Compatibility (EMC) Framework requirements of the Australian Communication Authority (ACA).

### **2.13.3 FCC verification**

These drives are intended to be contained solely within a personal computer or similar enclosure (not attached as an external device). As such, each drive is considered to be a subassembly even when it is individually marketed to the customer. As a subassembly, no Federal Communications Commission verification or certification of the device is required.

Seagate Technology LLC has tested this device in enclosures as described above to ensure that the total assembly (enclosure, disc drive, motherboard, power supply, etc.) does comply with the limits for a Class B computing device, pursuant to Subpart J, Part 15 of the FCC rules. Operation with noncertified assemblies is likely to result in interference to radio and television reception.

Radio and television interference. This equipment generates and uses radio frequency energy and if not installed and used in strict accordance with the manufacturer's instructions, may cause interference to radio and television reception.

This equipment is designed to provide reasonable protection against such interference in a residential installation. However, there is no guarantee that interference will not occur in a particular installation. If this equipment does cause interference to radio or television, which can be determined by turning the equipment on and off, you are encouraged to try one or more of the following corrective measures:

- Reorient the receiving antenna.
- Move the device to one side or the other of the radio or TV.
- Move the device farther away from the radio or TV.
- Plug the computer into a different outlet so that the receiver and computer are on different branch outlets.

If necessary, you should consult your dealer or an experienced radio/television technician for additional suggestions. You may find helpful the following booklet prepared by the Federal Communications Commission: *How to Identify and Resolve Radio-Television Interference Problems*. This booklet is available from the Superintendent of Documents, U.S. Government Printing Office, Washington, DC 20402. Refer to publication number 004-000-00345-4.

## **2.14 Environmental protection**

Seagate designs its products to meet environmental protection requirements worldwide, including regulations restricting certain chemical substances.

### **2.14.1 European Union Restriction of Hazardous Substances (RoHS)**

The European Union Restriction of Hazardous Substances (RoHS) Directive restricts the presence of chemical substances, including Lead (Pb), in electronic products effective July 2006..

A number of parts and materials in Seagate products are procured from external suppliers. We rely on the representations of our suppliers regarding the presence of RoHS substances in these parts and materials. Our supplier contracts require compliance with our chemical substance restrictions, and our suppliers document their compliance with our requirements by providing material content declarations for all parts and materials for the disc drives documented in this publication. Current supplier declarations include disclosure of the inclusion of any RoHS-regulated substance in such parts or materials.

Seagate also has internal systems in place to ensure ongoing compliance with the RoHS Directive and all laws and regulations which restrict chemical content in electronic products. These systems include standard operating procedures that ensure that restricted substances are not utilized in our manufacturing operations, laboratory analytical validation testing, and an internal auditing process to ensure that all standard operating procedures are complied with.

## **2.15 Corrosive environment**

Seagate electronic drive components pass accelerated corrosion testing equivalent to 10 years exposure to light industrial environments containing sulfurous gases, chlorine and nitric oxide, classes G and H per ASTM B845. However, this accelerated testing cannot duplicate every potential application environment. Users should use caution exposing any electronic components to uncontrolled chemical pollutants and corrosive chemicals as electronic drive component reliability can be affected by the installation environment. The silver, copper, nickel and gold films used in Seagate products are especially sensitive to the presence of sulfide, chloride, and nitrate contaminants. Sulfur is found to be the most damaging. In addition, electronic components should never be exposed to condensing water on the surface of the printed circuit board assembly (PCBA) or exposed to an ambient relative humidity greater than 95%. Materials used in cabinet fabrication, such as vulcanized rubber, that can outgas corrosive compounds should be minimized or eliminated. The useful life of any electronic equipment may be extended by replacing materials near circuitry with sulfide-free alternatives.





## 3.0 Configuring and mounting the drive

---

This section contains the specifications and instructions for configuring and mounting the drive.

### 3.1 Handling and static discharge precautions

After unpacking, and before installation, the drive may be exposed to potential handling and electrostatic discharge (ESD) hazards. Observe the following standard handling and static-discharge precautions:

**Caution:**

- Before handling the drive, put on a grounded wrist strap, or ground yourself frequently by touching the metal chassis of a computer that is plugged into a grounded outlet. Wear a grounded wrist strap throughout the entire installation procedure.
- Handle the drive by its edges or frame *only*.
- The drive is extremely fragile—handle it with care. Do not press down on the drive top cover.
- Always rest the drive on a padded, antistatic surface until you mount it in the computer.
- Do not touch the connector pins or the printed circuit board.
- Do not remove the factory-installed labels from the drive or cover them with additional labels. Removal voids the warranty. Some factory-installed labels contain information needed to service the drive. Other labels are used to seal out dirt and contamination.

### 3.2 Breather filter hole precautions

This section contains information regarding the precautions which should be taken regarding the breather filter hole in Seagate hard disc drives. Proper precautions should be taken to ensure full functionality and prevent possible damage to the drive.

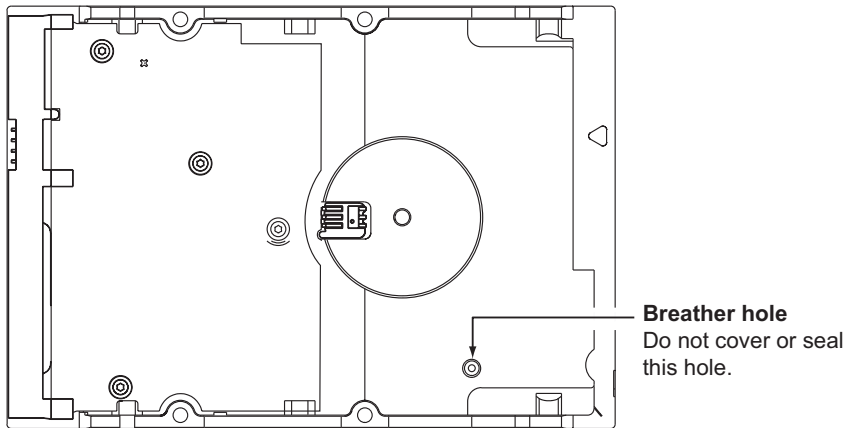

**Figure 3 Breather filter hole location**

**Caution: Do not cover, seal, or insert any object into this hole.**

This hole has two purposes:

- To allow condensation inside the hard disc to escape
- To allow air pressure inside the hard disc to equalize with ambient pressure

**Note.** If this hole is covered, sealed, or penetrated by any object, the drive reliability may be compromised and could lead to permanent damage. Covering or sealing this hole voids the warranty.

## 3.3 Jumper settings

### 3.3.1 Master/slave configuration

The options jumper block shown in Figure 4 is used to configure the drive for operation. It is the 8-pin dual header between the interface connector and the power connector. Use the following settings to configure the drive as a master or a slave.

**Master or single drive.** The drive is configured at the factory for a master or single-drive operation with a jumper set on pins 7 and 8.

**Drive as slave.** Remove all jumpers.

**Drive as master with a non-ATA-compatible slave.**

Use this jumper setting *only* if the drive does not work as a master with no jumpers installed.

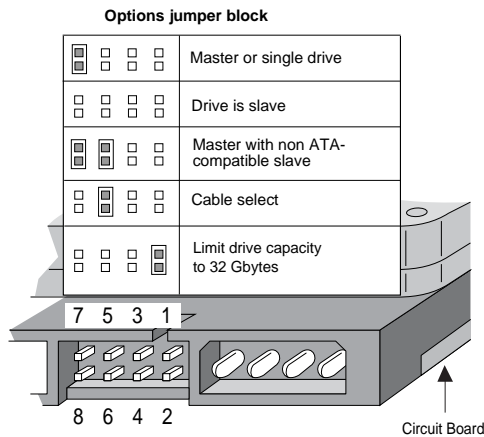

Figure 4 Master/slave jumper settings

### 3.3.2 Cable-select option

Computers that use cable select determine the master and slave drives by selecting or deselecting pin 28, CSEL, on the interface bus. Master and slave drives are determined by their physical position on the cable. To enable cable select, set a jumper on pins 5 and 6 as shown in Figure 4. Refer to your computer manual to determine whether your computer supports this option.

### 3.3.3 Alternate capacity jumper

Some older computers may “hang” at startup if their BIOS detects a disc drive with a capacity greater than 32 Gbytes. This limits the drive’s capacity to 32 Gbytes when the alternate capacity jumper is used. To access the full capacity of the drive, you can:

- Update the BIOS
- Use third-party software such as DiscWizard™ or Disk Manager
- Use a third-party host adapter

For drives with capacities greater than 32 Gbytes, the alternate capacity jumper changes the total available LBA sectors to 32 Gbytes to solve issues with some BIOS during power on. The ATA Set Features subcommand “F1<sub>H</sub> Report Full Capacity Available” causes Identify Data words 60 and 61 to report the full capacity. See Section 4.1.3 on page 48 for more details on the Set Features command.

Windows XP, Windows Me, Windows 98 or newer versions are needed to support drives with capacities greater than 32 Gbytes.

### 3.3.4 Ultra ATA/100 cable

An 80-conductor 40-pin cable is required to run Ultra DMA mode 3, mode 4, and mode 5. This cable uses even-numbered conductors connected to the ground pins to improve signal integrity.

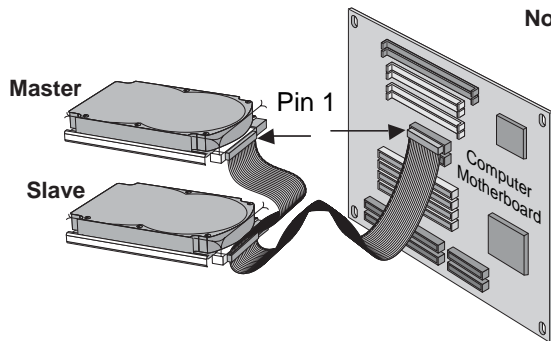

**Note.** If you are using a 40-pin, 80-conductor cable, attach the blue connector to the motherboard, the black connector to the master drive, and the gray connector to the slave.

**Figure 5** Ultra ATA cable connectors

**Note.** The drive supports both host and drive cable detection. The host detects the 80-conductor cable by sampling pin 34, CBLID-, on the interface bus. The drive detects the 80-conductor cable by sensing a capacitor at the host side through the CBLID- signal. The result is reported in a Fast Rise Detected bit (bit 13 of word 93 in the Identify drive parameter block).

## 3.4 Drive mounting

You can mount the drive in any orientation using four screws in the side-mounting holes or four screws in the bottom-mounting holes. See Figure 6 for drive mounting dimensions. Follow these important mounting precautions when mounting the drive:

- Allow a minimum clearance of 0.030 inches (0.76 mm) around the entire perimeter of the drive for cooling.
- Use only 6-32 UNC mounting screws.
- Do not overtighten the mounting screws (maximum torque: 6 inch-lb.).
- Do not use a drive interface cable that is more than 18 inches long.

**Notes:**

- 1. Dimensions are shown in inches (mm).
- 2 Dimensions per SFF-8301 specification.

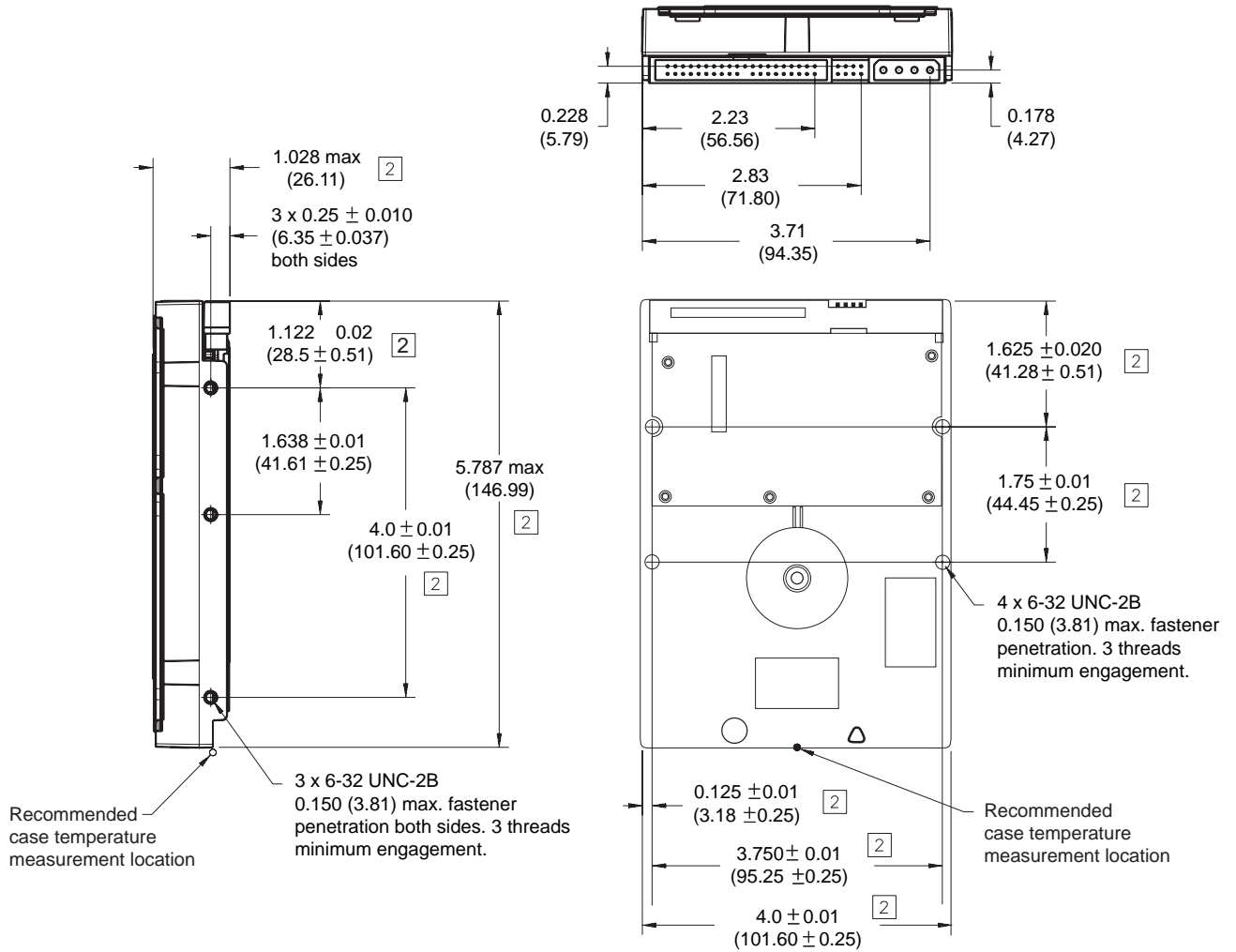

**Figure 6 Mounting dimensions—top, side and end view**



## 4.0 ATA interface

These drives use the industry-standard ATA task file interface that supports 16-bit data transfers. It supports ATA programmed input/output (PIO) modes 0–4; multiword DMA modes 0–2, and Ultra DMA modes 0–5. The drive also supports the use of the IORDY signal to provide reliable high-speed data transfers.

You can use a daisy-chain cable to connect two drives to a single AT host bus. For detailed information about the ATA interface, refer to the draft of *AT Attachment with Packet Interface Extension (ATA/ATAPI-7)*, *NCITS T13 1410D*, subsequently referred to as the *Draft ATA-7 Standard*.

### 4.1 ATA interface signals and connector pins

Figure 7 on page 41 summarizes the signals on the ATA interface connector that the drive supports. For a detailed description of these signals, refer to the *Draft ATA-7 Standard*.

Drive pin #	Signal name	Host pin # and signal description
1	Reset-	1 Hardware Reset
2	Ground	2 Ground
3	DD7	3 Host Data Bus Bit 7
4	DD8	4 Host Data Bus Bit 8
5	DD6	5 Host Data Bus Bit 6
6	DD9	6 Host Data Bus Bit 9
7	DD5	7 Host Data Bus Bit 5
8	DD10	8 Host Data Bus Bit 10
9	DD4	9 Host Data Bus Bit 4
10	DD11	10 Host Data Bus Bit 11
11	DD3	11 Host Data Bus Bit 3
12	DD12	12 Host Data Bus Bit 12
13	DD2	13 Host Data Bus Bit 2
14	DD13	14 Host Data Bus Bit 13
15	DD1	15 Host Data Bus Bit 1
16	DD14	16 Host Data Bus Bit 14
17	DD0	17 Host Data Bus Bit 0
18	DD15	18 Device Data (15:0)
19	Ground	19 Ground
20	(removed)	20 (No Pin)
21	DMARQ	21 DMA Request
22	Ground	22 Ground
23	DIOW-	23 Device I/O Write:
	STOP	Stop Ultra DMA Burst
24	Ground	24 Ground
25	DIOR-	25 Device I/O Read:
	HDMARDY-	Host Ultra DMA Ready:
	HSTROBE	Host Ultra DMA Data Strobe
26	Ground	26 Ground
27	IORDY	27 I/O Channel Ready
	DDMARDY-	Device Ultra DMA Ready
	DSTROBE	Device Ultra DMA Data Strobe
28	CSEL	28 Cable Select
29	DMACK-	29 DMA Acknowledge
30	Ground	30 Ground
31	INTRQ	31 Device Interrupt
32	IOCS16-	32 Reserved
33	DA1	33 Host Address Bus Bit 1
34	PDIAG-	34 Passed Diagnostics
	CBLID-	Cable Assembly Type Identifier
35	DA0	35 Device Address (2:0)
36	DA2	36 Device Address (2:0)
37	CS0-	37 Chip Select (1:0)
38	CS1-	38 Chip Select (1:0)
39	DASP-	39 Drive Active/Slave Present
40	Ground	40 Ground

Pins 28, 34 and 39 are used for master-slave communication (details shown below).

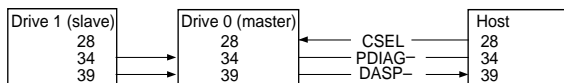

Figure 7 I/O pins and supported ATA signals

#### 4.1.1 Supported ATA commands

The following table lists ATA-standard commands that the drive supports. For a detailed description of the ATA commands, refer to the *Draft ATA-7 Standard*. See “S.M.A.R.T. commands” on page 49 for details and sub-commands used in the S.M.A.R.T. implementation.

**Table 16: Supported ATA commands**

Command name	Command code (in hex)
Check Power Mode	98 <sub>H</sub> or E5 <sub>H</sub>
Device Configuration Freeze Lock	B1 <sub>H</sub> / C1 <sub>H</sub>
Device Configuration Identify	B1 <sub>H</sub> / C2 <sub>H</sub>
Device Configuration Restore	B1 <sub>H</sub> / C0 <sub>H</sub>
Device Configuration Set	B1 <sub>H</sub> / C3 <sub>H</sub>
Device Reset	08 <sub>H</sub>
Download Microcode	92 <sub>H</sub>
Execute Device Diagnostics	90 <sub>H</sub>
Flush Cache	E7 <sub>H</sub>
Flush Cache Extended	EA <sub>H</sub>
Format Track	50 <sub>H</sub>
Identify Device	EC <sub>H</sub>
Idle	97 <sub>H</sub> or E3 <sub>H</sub>
Idle Immediate	95 <sub>H</sub> or E1 <sub>H</sub>
Initialize Device Parameters	91 <sub>H</sub>
Read Buffer	E4 <sub>H</sub>
Read DMA	C8 <sub>H</sub>
Read DMA Extended	25 <sub>H</sub>
Read DMA Without Retries	C9 <sub>H</sub>
Read Log Ext	2F <sub>H</sub>
Read Multiple	C4 <sub>H</sub>
Read Multiple Extended	29 <sub>H</sub>
Read Native Max Address	F8 <sub>H</sub>
Read Native Max Address Extended	27 <sub>H</sub>
Read Sectors	20 <sub>H</sub>
Read Sectors Extended	24 <sub>H</sub>
Read Sectors Without Retries	21 <sub>H</sub>
Read Verify Sectors	40 <sub>H</sub>
Read Verify Sectors Extended	42 <sub>H</sub>
Read Verify Sectors Without Retries	41 <sub>H</sub>
Recalibrate	10 <sub>H</sub>
Security Disable Password	F6 <sub>H</sub>
Security Erase Prepare	F3 <sub>H</sub>



Command name	Command code (in hex)
Security Erase Unit	F4 <sub>H</sub>
Security Freeze	F5 <sub>H</sub>
Security Set Password	F1 <sub>H</sub>
Security Unlock	F2 <sub>H</sub>
Seek	70 <sub>H</sub>
Set Features	EF <sub>H</sub>
Set Max Address Note: Individual Set Max Address commands are identified by the value placed in the Set Max Features register as defined to the right.	F9 <sub>H</sub> Address: 00 <sub>H</sub> Password: 01 <sub>H</sub> Lock: 02 <sub>H</sub> Unlock: 03 <sub>H</sub> Freeze Lock: 04 <sub>H</sub>
Set Max Address Extended	37 <sub>H</sub>
Set Multiple Mode	C6 <sub>H</sub>
Sleep	99 <sub>H</sub> or E6 <sub>H</sub>
S.M.A.R.T. Disable Operations	B0 <sub>H</sub> / D9 <sub>H</sub>
S.M.A.R.T. Enable/Disable Autosave	B0 <sub>H</sub> / D2 <sub>H</sub>
S.M.A.R.T. Enable Operations	B0 <sub>H</sub> / D8 <sub>H</sub>
S.M.A.R.T. Execute Offline	B0 <sub>H</sub> / D4 <sub>H</sub>
S.M.A.R.T. Read Attribute Thresholds	B0 <sub>H</sub> / D1 <sub>H</sub>
S.M.A.R.T. Read Data	B0 <sub>H</sub> / D0 <sub>H</sub>
S.M.A.R.T. Read Log Sector	B0 <sub>H</sub> / D5 <sub>H</sub>
S.M.A.R.T. Return Status	B0 <sub>H</sub> / DA <sub>H</sub>
S.M.A.R.T. Save Attribute Values	B0 <sub>H</sub> / D3 <sub>H</sub>
S.M.A.R.T. Write Log Sector	B0 <sub>H</sub> / D6 <sub>H</sub>
Standby	96 <sub>H</sub> or E2 <sub>H</sub>
Standby Immediate	94 <sub>H</sub> or E0 <sub>H</sub>
Write Buffer	E8 <sub>H</sub>
Write DMA	CA <sub>H</sub>
Write DMA Extended	35 <sub>H</sub>
Write DMA Without Retries	CB <sub>H</sub>
Write Log Extended	3F <sub>H</sub>
Write Multiple	C5 <sub>H</sub>
Write Multiple Extended	39 <sub>H</sub>
Write Sectors	30 <sub>H</sub>
Write Sectors Without Retries	31 <sub>H</sub>
Write Sectors Extended	34 <sub>H</sub>

#### 4.1.2 Identify Device command

The Identify Device command (command code EC<sub>H</sub>) transfers information about the drive to the host following power up. The data is organized as a single 512-byte block of data, whose contents are shown in the Table 16 on page 42. All reserved bits or words should be set to zero. Parameters listed with an “x” are drive-specific or vary with the state of the drive. See Section 2.0 on page 3 for default parameter settings.

The following commands contain drive-specific features that may not be included in the *Draft ATA-7 Standard*.

Word	Description	Value
0	Configuration information: <ul style="list-style-type: none"> <li>• Bit 15: 0 = ATA; 1 = ATAPI</li> <li>• Bit 7: removable media</li> <li>• Bit 6: removable controller</li> <li>• Bit 0: reserved</li> </ul>	0C5A <sub>H</sub>
1	Number of logical cylinders	16,383
2	ATA-reserved	0000 <sub>H</sub>
3	Number of logical heads	16
4	Retired	0000 <sub>H</sub>
5	Retired	0000 <sub>H</sub>
6	Number of logical sectors per logical track: 63	003F <sub>H</sub>
7–9	Retired	0000 <sub>H</sub>
10–19	Serial number: (20 ASCII characters, 0000 <sub>H</sub> = none)	ASCII
20	Retired	0000 <sub>H</sub>
21	Retired	0400 <sub>H</sub>
22	Obsolete	0000 <sub>H</sub>
23–26	Firmware revision (8 ASCII character string, padded with blanks to end of string)	x.xx
27–46	Drive model number (40 ASCII characters, padded with blanks to end of string)	ST3xxxxxA
47	(Bits 7–0) Maximum sectors per interrupt on Read multiple and Write multiple (16)	8010 <sub>H</sub>
48	Reserved	0000 <sub>H</sub>
49	Standard Standby timer, IORDY supported and may be disabled	2F00 <sub>H</sub>
50	ATA-reserved	0000 <sub>H</sub>
51	PIO data-transfer cycle timing mode	0200 <sub>H</sub>
52	Retired	0200 <sub>H</sub>
53	Words 54–58, 64–70 and 88 are valid	0007 <sub>H</sub>
54	Number of current logical cylinders	xxxx <sub>H</sub>
55	Number of current logical heads	xxxx <sub>H</sub>
56	Number of current logical sectors per logical track	xxxx <sub>H</sub>
57–58	Current capacity in sectors	xxxx <sub>H</sub>
59	Number of sectors transferred during a Read Multiple or Write Multiple command	xxxx <sub>H</sub>

Word	Description	Value
60–61	Total number of user-addressable LBA sectors available (see Section 2.2 for related information)  *Note: The maximum value allowed in this field is: 0FFFFFFFh (268,435,455 sectors, 137 Gbytes). Drives with capacities over 137 Gbytes will have 0FFFFFFFh in this field and the actual number of user-addressable LBAs specified in words 100-103. This is required for drives that support the 48-bit addressing feature.	ST3402111A = 78,165,360 ST3802110A = 156,301,488 ST3120213A = 0FFFFFFFh* ST3120814A = 0FFFFFFFh* ST3160212A = 0FFFFFFFh* ST3160812A = 0FFFFFFFh* ST3200827A = 0FFFFFFFh* ST3250624A = 0FFFFFFFh* ST3250824A = 0FFFFFFFh* ST3300622A = 0FFFFFFFh* ST3300822A = 0FFFFFFFh* ST3320633A = 0FFFFFFFh* ST3320833A = 0FFFFFFFh* ST3400633A = 0FFFFFFFh* ST3400833A = 0FFFFFFFh* ST3500641A = 0FFFFFFFh* ST3500841A = 0FFFFFFFh*
62	Retired	0000 <sub>H</sub>
63	Multiword DMA active and modes supported (see note following this table)	xx07 <sub>H</sub>
64	Advanced PIO modes supported (modes 3 and 4 supported)	0003 <sub>H</sub>
65	Minimum multiword DMA transfer cycle time per word (120 nsec)	0078 <sub>H</sub>
66	Recommended multiword DMA transfer cycle time per word (120 nsec)	0078 <sub>H</sub>
67	Minimum PIO cycle time without IORDY flow control (240 nsec)	00F0 <sub>H</sub>
68	Minimum PIO cycle time with IORDY flow control (120 nsec)	0078 <sub>H</sub>
69–74	ATA-reserved	0000 <sub>H</sub>
75	Queue depth	0000 <sub>H</sub>
76–79	SATA-specific	xxxx <sub>H</sub>
80	Major version number	007E <sub>H</sub>
81	Minor version number	0000 <sub>H</sub>
82	Command sets supported	346B <sub>H</sub>
83	Command sets supported	7D01 <sub>H</sub>
84	Command sets support extension	4003 <sub>H</sub>
85	Command sets enabled	34xx <sub>H</sub>
86	Command sets enabled	3xxx <sub>H</sub>
87	Command sets enable extension	4003 <sub>H</sub>
88	Ultra DMA support and current mode (see note following this table)	xx3F <sub>H</sub>
89	Security erase time	0000 <sub>H</sub>
90	Enhanced security erase time	0000 <sub>H</sub>
92	Master password revision code	FFFE <sub>H</sub>
93	Hardware reset value (see description following this table)	xxxx <sub>H</sub>
95–99	ATA-reserved	0000 <sub>H</sub>

Word	Description	Value
100–103	Total number of user-addressable LBA sectors available (see Section 2.2 for related information). These words are required for drives that support the 48-bit addressing feature. Maximum value: 0000FFFFFFFFFh.	ST3402111A = 78,165,360 ST3802110A = 156,301,488 ST3120213A = 234,441,648 ST3120814A = 234,441,648 ST3160212A = 312,581,808 ST3160812A = 312,581,808 ST3200827A = 390,721,968 ST3250624A = 488,397,168 ST3250824A = 488,397,168 ST3300622A = 586,072,368 ST3300822A = 586,072,368 ST3320633A = 625,142,448 ST3320633A = 625,142,448 ST3400633A = 781,422,768 ST3400833A = 781,422,768 ST3500641A = 976,773,168 ST3500841A = 976,773,168
104–127	ATA-reserved	0000 <sub>H</sub>
128	Security status	0001 <sub>H</sub>
129–159	Seagate-reserved	xxxx <sub>H</sub>
160–254	ATA-reserved	0000 <sub>H</sub>
255	Integrity word	xxA5 <sub>H</sub>

**Note.** Advanced Power Management (APM) and Automatic Acoustic Management (AAM) features are not supported

**Note.** See the bit descriptions below for words 63, 88, and 93 of the Identify Drive data:

Description (if bit is set to 1)		
	Bit	Word 63
	0	Multiword DMA mode 0 is supported.
	1	Multiword DMA mode 1 is supported.
	2	Multiword DMA mode 2 is supported.
	8	Multiword DMA mode 0 is currently active.
	9	Multiword DMA mode 1 is currently active.
	10	Multiword DMA mode 2 is currently active.
	Bit	Word 88
	0	Ultra DMA mode 0 is supported.
	1	Ultra DMA mode 1 is supported.
	2	Ultra DMA mode 2 is supported.
	3	Ultra DMA mode 3 is supported.
	4	Ultra DMA mode 4 is supported.
	5	Ultra DMA mode 5 is supported.
	8	Ultra DMA mode 0 is currently active.
	9	Ultra DMA mode 1 is currently active.
	10	Ultra DMA mode 2 is currently active.
	11	Ultra DMA mode 3 is currently active.

	12	Ultra DMA mode 4 is currently active.
	13	Ultra DMA mode 5 is currently active.
	<b>Bit</b>	<b>Word 93</b>
	13	1 = 80-conductor cable detected, CBLID above $V_{IH}$ 0 = 40-conductor cable detected, CBLID below $V_{IL}$

### 4.1.3 Set Features command

This command controls the implementation of various features that the drive supports. When the drive receives this command, it sets BSY, checks the contents of the Features register, clears BSY and generates an interrupt. If the value in the register does not represent a feature that the drive supports, the command is aborted. Power-on default has the read look-ahead and write caching features enabled. The acceptable values for the Features register are defined as follows:

02 <sub>H</sub>	Enable write cache ( <i>default</i> ).
03 <sub>H</sub>	Set transfer mode (based on value in Sector Count register). Sector Count register values:
00 <sub>H</sub>	Set PIO mode to default (PIO mode 2).
01 <sub>H</sub>	Set PIO mode to default and disable IORDY (PIO mode 2).
08 <sub>H</sub>	PIO mode 0
09 <sub>H</sub>	PIO mode 1
0A <sub>H</sub>	PIO mode 2
0B <sub>H</sub>	PIO mode 3
0C <sub>H</sub>	PIO mode 4 ( <i>default</i> )
20 <sub>H</sub>	Multiword DMA mode 0
21 <sub>H</sub>	Multiword DMA mode 1
22 <sub>H</sub>	Multiword DMA mode 2
40 <sub>H</sub>	Ultra DMA mode 0
41 <sub>H</sub>	Ultra DMA mode 1
42 <sub>H</sub>	Ultra DMA mode 2
43 <sub>H</sub>	Ultra DMA mode 3
44 <sub>H</sub>	Ultra DMA mode 4
45 <sub>H</sub>	Ultra DMA mode 5
55 <sub>H</sub>	Disable read look-ahead (read cache) feature.
82 <sub>H</sub>	Disable write cache.
AA <sub>H</sub>	Enable read look-ahead (read cache) feature ( <i>default</i> ).
F1 <sub>H</sub>	Report full capacity available

**Note.** At power-on, or after a hardware or software reset, the default values of the features are as indicated above.

#### 4.1.4 S.M.A.R.T. commands

S.M.A.R.T. provides near-term failure prediction for disc drives. When S.M.A.R.T. is enabled, the drive monitors predetermined drive attributes that are susceptible to degradation over time. If self-monitoring determines that a failure is likely, S.M.A.R.T. makes a status report available to the host. Not all failures are predictable. S.M.A.R.T. predictability is limited to the attributes the drive can monitor. For more information on S.M.A.R.T. commands and implementation, see the *Draft ATA-7 Standard*.

SeaTools diagnostic software activates a built-in drive self-test (DST S.M.A.R.T. command for D4<sub>H</sub>) that eliminates unnecessary drive returns. The diagnostic software ships with all new drives and is also available at: <http://seatools.seagate.com>.

This drive is shipped with S.M.A.R.T. features disabled. You must have a recent BIOS or software package that supports S.M.A.R.T. to enable this feature. The table below shows the S.M.A.R.T. command codes that the drive uses.

Code in features register	S.M.A.R.T. command
D0 <sub>H</sub>	S.M.A.R.T. Read Data
D2 <sub>H</sub>	S.M.A.R.T. Enable/Disable Attribute Autosave
D3 <sub>H</sub>	S.M.A.R.T. Save Attribute Values
D4 <sub>H</sub>	S.M.A.R.T. Execute Off-line Immediate (runs DST)
D5 <sub>H</sub>	S.M.A.R.T. Read Log Sector
D6 <sub>H</sub>	S.M.A.R.T. Write Log Sector
D8 <sub>H</sub>	S.M.A.R.T. Enable Operations
D9 <sub>H</sub>	S.M.A.R.T. Disable Operations
DA <sub>H</sub>	S.M.A.R.T. Return Status

**Note.** If an appropriate code is not written to the Features Register, the command is aborted and 0x04 (abort) is written to the Error register.





## 5.0 Seagate Technology support services

---

### Internet

For information regarding Seagate products and services, visit [www.seagate.com](http://www.seagate.com). Worldwide support is available 24 hours daily by email for your questions.

### Presales Support:

Presales@Seagate.com

### Technical Support:

DiscSupport@Seagate.com

### Warranty Support:

<http://www.seagate.com/support/service/index.html>

### mySeagate

my.seagate.com is the industry's first Web portal designed specifically for OEMs and distributors. It provides self-service access to critical applications, personalized content and the tools that allow our partners to manage their Seagate account functions. Submit pricing requests, orders and returns through a single, password-protected Web interface-anytime, anywhere in the world.

### spp.seagate.com

spp.seagate.com supports Seagate resellers with product information, program benefits and sales tools. You may register for customized communications that are not available on the web. These communications contain product launch, EOL, pricing, promotions and other channel-related information. To learn more about the benefits or to register, go to spp.seagate.com, any time, from anywhere in the world.

## Seagate Service Centers

### Presales Support

Our Presales Support staff can help you determine which Seagate products are best suited for your specific application or computer system, as well as product availability and compatibility.

### Technical Support

Seagate technical support is available to assist you online at [support.seagate.com](http://support.seagate.com) or through one of our call centers. Have your system configuration information and your "ST" model number available.

**SeaTDD™ (+1-405-324-3655)** is a telecommunications device for the deaf (TDD). You can send questions or comments 24 hours daily and exchange messages with a technical support specialist during normal business hours for the call center in your region.

## Customer Service Operations

### Warranty Service

Seagate offers worldwide customer support for Seagate products. Seagate distributors, OEMs and other direct customers should contact their Seagate Customer Service Operations (CSO) representative for warranty-related issues. Resellers or end users of drive products should contact their place of purchase or Seagate warranty service for assistance. Have your serial number and model or part number available.

### Data Recovery Services

Seagate offers data recovery services for all formats and all brands of storage media. Our data recovery services labs are currently located throughout the world. . Additional information, including an online request form and data loss prevention resources, is available at <http://services.seagate.com/index.aspx>

### Authorized Service Centers

Seagate Service Centers are available on a global basis for the return of defective products. Contact your customer support representative for the location nearest you.

### USA/Canada/Latin America support services

For an extensive list of telephone numbers to technical support, presales and warranty service in USA/Canada/Latin America, including business hours, go to the "Contact Us" page on [www.seagate.com](http://www.seagate.com).

## Global Customer Support

### Presales, Technical, and Warranty Support

Call Center	Toll-free	Direct dial
USA, Canada, and Mexico	1-800-SEAGATE	+1-405-324-4700

### Data Recovery Services

Call Center	Toll-free	Direct dial	FAX
USA, Canada, and Mexico	1-800-475-01435	+1-905-474-2162	1-800-475-0158 +1-905-474-2459

## Europe, the Middle East and Africa Support Services

For an extensive list of telephone numbers to technical support, presales and warranty service in Europe, the Middle East and Africa, go to the "Contact Us" page on [www.seagate.com](http://www.seagate.com).

## Asia/Pacific Support Services

For an extensive list of telephone numbers to technical support, presales and warranty service in Asia/Pacific, go to the "Contact Us" page on [www.seagate.com](http://www.seagate.com).

# Index

## A

acoustics 29  
Active mode 26  
agency certification (regulatory) 31  
alternate capacity jumper 37  
altitude 27  
ambient conditions 3  
ambient temperature 22, 27  
areal density 1, 21  
ATA interface 41  
ATA-standard commands 42  
Australian C-Tick 32  
autodetection 1  
average seek time 22

## B

BIOS 37  
BPI 21  
breather filter hole precautions 36  
buffer 21  
burst 1

## C

cable 38  
cable select 1  
cable-select option 37  
cache 1, 21  
case temperature 27  
CE mark 31  
certification 31  
Check Power Mode 42  
commands 42  
compliance 31  
conducted noise 26  
conducted RF immunity 30  
configuring the drive 35  
connector pins 41  
connectors 38  
contact start-stop cycles 31  
Corrosive environment 33  
CSA C22.2 (950) 31  
CSEL 37  
C-Tick 32  
current profile 25  
cycles 31

## D

data-transfer rates 1  
DC power 23  
density 21

Device Configuration Freeze Lock 42  
Device Configuration Identify 42  
Device Configuration Restore 42  
Device Configuration Set 42  
Device Reset 42  
diagnostic software 1, 49  
DiscWizard 37  
Disk Manager 37  
dissipation 24, 25  
Download Microcode 42  
drive diagnostics 22  
drive monitoring 1  
drive self-test 1, 49  
DST 49

## E

electrical fast transient 30  
electromagnetic compatibility 31  
Electromagnetic Compatibility Directive 31  
electromagnetic immunity 30  
electrostatic discharge 30  
EMC compliance 31  
EN 60950 31  
enclosures 32  
environmental specifications 27  
EPRML 21  
error-correction algorithms 1  
errors 31  
European Union 31  
Execute Device Diagnostics 42

## F

failure prediction 49  
FCC verification 32  
Features register 48  
Flush Cache 42  
Flush Cache Extended 42  
Format Track 42  
formatted capacity 20  
frequency 30

## G

guaranteed sectors 20

## H

handling 35  
heads 1  
height 22  
humidity 27

## I

I/O data-transfer rate 21  
Identify Device 42

Identify Device command 44  
Idle 42  
Idle and Standby timers 26  
Idle Immediate 42  
Idle mode 26  
Idle mode power 23  
IEC950 31  
Information Technology Equipment 31  
Initialize Device Parameters 42  
interface 21, 41  
interface signals 41  
interference 32  
interleave 21  
internal data-transfer rate OD 21  
ISO document 7779 29

## J

jumper settings 37

## K

Korean RRL 31

## L

LBA mode 20  
length 22  
logical geometry 20

## M

maintenance 31  
master 37  
master/slave 1  
Master/slave configuration 37  
maximum temperature 27  
measurement locations 27  
modes 41  
monitoring 1  
mounting the drive 35, 38

## N

noise 26  
nominal power 3  
nonoperating shock 28  
nonoperating vibration 28  
nonrecoverable read errors 31

## O

operating 24, 25  
operating power and current 23  
operating shock 28  
operating vibration 28  
orientation 38

## P

physical characteristics 22  
pins 41  
PIO 41  
power consumption 23  
power dissipation 24, 25  
power management 26  
power specifications 23  
power-management modes 26  
Power-on to Ready 22  
precautions 38  
preventive maintenance 31  
programmable power management 26

## R

radiated RF immunity 30  
radio and television interference 32  
radio frequency 30  
random track location 23  
Read Buffer 42  
Read DMA 42  
Read DMA Extended 42  
Read DMA without Retries 42  
read errors 31  
Read Log Ext 42  
Read Multiple 1, 42  
Read Multiple Extended 42  
Read Native Max Address 42  
Read Native Max Address Extended 42  
Read Sectors 42  
Read Sectors Extended 42  
Read Sectors Without Retries 42  
Read Verify Sectors 42  
Read Verify Sectors Extended 42  
Read Verify Sectors Without Retries 42  
read/write power and current 23  
Recalibrate 42  
recording and interface technology 21  
recording density 21  
recording heads 1  
recording method 21  
register 48  
relative humidity 27  
reliability 31  
resistance 26  
resistive load 26  
RF 30  
RoHS 33

## S

S.M.A.R.T. commands 49  
S.M.A.R.T. Disable Operations 43  
S.M.A.R.T. drive monitoring 1  
S.M.A.R.T. Enable Operations 43

- S.M.A.R.T. Enable/Disable Autosave 43
- S.M.A.R.T. Execute Offline 43
- S.M.A.R.T. Read Attribute Thresholds 43
- S.M.A.R.T. Read Data 43
- S.M.A.R.T. Read Log Sector 43
- S.M.A.R.T. Return Status 43
- S.M.A.R.T. Save Attribute Values 43
- S.M.A.R.T. Write Log sector 43
- safety certification 31
- screws 38
- SeaTools 1, 49
- sectors 20
- Security Disable Password 42
- Security Erase Prepare 42
- Security Erase Unit 43
- Security Freeze 43
- Security Set Password 43
- Security Unlock 43
- Seek 43
- seek mode 23
- seek time 22
- Seeking 24, 25
- servo electronics 23
- Set Features 43
- Set Features command 48
- Set Max Address 43
- Set Max Address Extended 43
- Set Multiple Mode 43
- shock 28
- signals 41
- single-track seeks 22
- slave 37
- Sleep 24, 25, 43
- Sleep mode 26
- sound 29
- specifications 3
- spindle speed 21
- Spinup 24, 25
- spinup power 23
- Standby 24, 25, 43
- Standby Immediate 43
- Standby mode 23, 26
- Standby to Ready 22
- start/stop times 22
- start-stop cycles 31
- static-discharge precautions 35
- stop times 22
- subassembly 32
- support services 51
- surge immunity 30

## T

- technical support services 51
- temperature 27
- temperature gradient 27

- timers 26
- TMR 1
- track density 21
- track-to-track seek time 22
- TUV North America 31

## U

- UL 1950 31
- Ultra ATA/100 38
- Ultra DMA 38

## V

- vibration 28
- voltage 26
- voltage dips, interrupts 30
- voltage tolerance 26

## W

- weight 22
- wet bulb temperature 27
- width 22
- Write Buffer 43
- Write DMA 43
- Write DMA Extended 43
- Write DMA Without Retries 43
- Write Log Extended 43
- Write Multiple 1, 43
- Write Multiple Extended 43
- Write Sectors 43
- Write Sectors Extended 43
- Write Sectors Without Retries 43







**Seagate Technology LLC**  
**920 Disc Drive, Scotts Valley, California 95066-4544, USA**  
*Publication Number: 100389997, Rev. F, Printed in U.S.A.*